



GEAR

Lubeletter

The World Leader in Synthetic Lubricants

Volume 30 Number 1

Full (Red) Circle Several years ago, Nye engineers worked with a Tier One manufacturer of wiper gear motors to improve the performance of the worm gears. The manufacturer was using a red-dyed grease that is used in many small motors. Nye sampled Rheolube 363F, an off-white, PAO/lithium soap grease with exceptional lubricating qualities for plastic-on-metal gears. Rheolube 363F came out on top, test after test.



Starting torque at -40°C for Rheolube 363F is less than 650 gm-cm, while red grease was over 10,000 gm-cm. Rheolube 363F's running torque was even lower, < 250 gm-cm compared to the red grease's >1000 gm-cm. The design engineers gave Rheolube 363F the nod, however the manufacturing engineers had a problem. Rheolube 363F wasn't red, which meant it couldn't be detected by the vision system on the automated assembly line. Nye's chemists added a red dye and commercialized Rheolube 363F RED, which worked with the vision system and outperformed the original red grease.

Eventually, the Tier One supplier was acquired by another manufacturer. New production technology was installed and the old vision inspection system was dismantled. Recently, a team of design engineers at this company began work on a new wiper motor design and came to Nye for grease samples. They specifically requested a red grease because they found old engineering notes that said, "Red grease needed for worm gear applications." Tradition. It's a tough nut to crack.

Robo Grease When Apex Dynamics, Inc., a subsidiary of the Apex Group in Taiwan, saw premature wear on the stainless steel gear teeth in its new helical planetary gear set, it knew the grease wasn't doing the job. Apex designs and manufactures a wide range of high precision gearboxes for automation engineering.

The application was no easy task for any grease. The gearbox would see input speeds as high as 10,000 RPM and was expected to deliver high torque, low

backlash, quiet operation, high efficiency — and long life in an industrial environment. Further, the oil, gellant, and additives that make up the grease had to be compatible with a urethane methacrylate anaerobic adhesive that was used inside the gearbox.

NyoGel 792D was made to order. It is a soft, silica-thickened, synthetic hydrocarbon grease with a temperature range of -30°C to 125°C. It is formulated specifically for gear trains, gear motors, worm and planetary gears. NyoGel 792D is an NLGI Grade 00 grease. It flows under shear and returns to a gel-like consistency when static. This "flow-ability" ensures continuous lubrication of the gears, which inhibits wear and extends gear life. Because this semi-fluid lubricant keeps only a thin film of lubricant on the gears, it also helps ensure the accuracy of robotic equipment. In a precision gear set even a thick lubricant film can cause a positioning error.

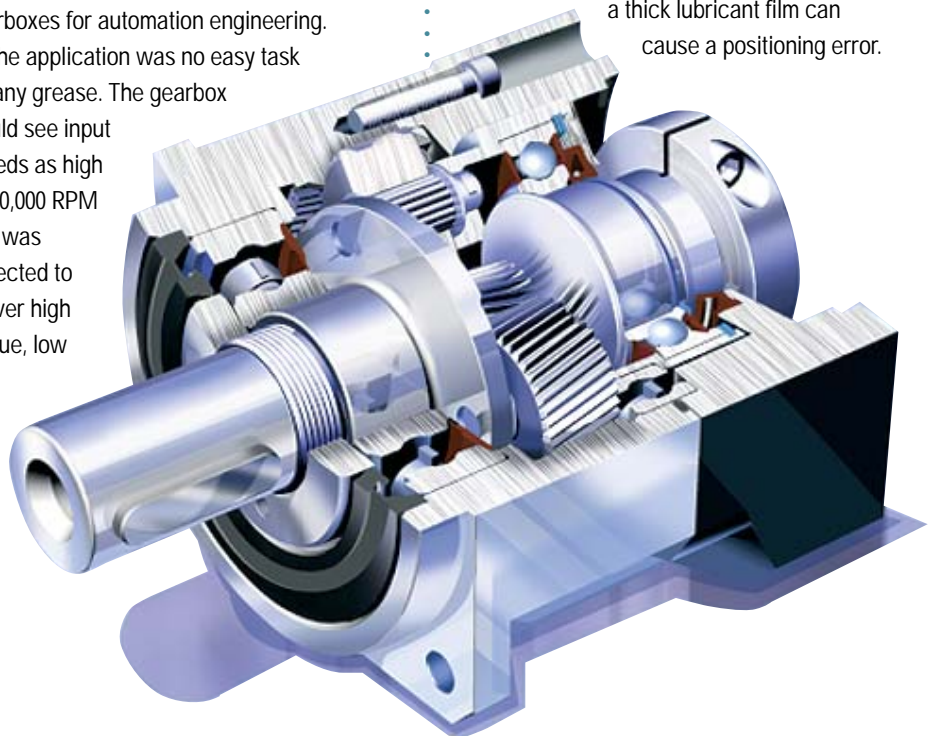



Jeff Lay,
Gearing Industry Director

IN GEAR

Since our last *Gear Lubeletter* in September 2001 a lot of things have changed in our world. Many of these changes were not what we were hoping for, nor do we wish to

see them happen again anytime soon. Fact is, our lives have changed significantly, but we will be stronger as a result.

Nye Lubricants was just one of many AGMA Gear Expo patrons who exhibited at Cobo Hall in Detroit, Michigan last October. The Gear Expo was one of the best in AGMA history with record attendance from both exhibitors and attendees. A great deal of pride and patriotism was on exhibit in nearly every booth. Both foreign and domestic exhibitors conducted business as usual and were proud to be a part of this trade show.

Despite the current economic situation, the Gear Industry and Nye Lubricants are doing very well. Nye continues to develop new products for a variety of applications including automotive wiper motors, power tool gearing, appliance timers, and industrial utility vehicle gearboxes. More and more customers are turning to synthetic lubricants from Nye to meet their design criteria — stateside and internationally, including Apex Dynamics, Inc., featured in this issue. Apex is a customer of our Taiwanese distributor, Formosachem Development Co., Ltd.

When your products need longer life or increased performance, I hope you'll turn to the gear team at Nye. Call me at 937-885-2312 or send me an e-mail at gearing@nyelubricants.com. We want to be your resource for synthetic lubricant technology.

Buy Smart With so many synthetic lubricants to choose from, it's wise to consult with a lubrication engineer before selecting a gear lubricant. But knowing something about the characteristics of the six basic families of synthetic lubricants will help you "buy smart."

Synthetic hydrocarbons, a.k.a. polyalphaolefins (PAOs), are the most widely used synthetic lubricants for gears and gearboxes. They offer good oxidative stability and wide-temperature performance from -60°C to 125°C. PAOs are compatible with many plastics used in gear fabrication. They're also relatively inexpensive compared with other synthetic fluids.



Synthetic esters are ideal for cut-metal and powdered-metal gearing if proper seals are used. Due to their affinity for metal, especially steel and iron, esters provide excellent wear protection. Because esters can withstand temperatures as high as 180°C, they have become the lubricants of choice for gearing in automotive superchargers and other severe-duty applications. A word of caution: Test material compatibility. Esters can attack certain plastics and elastomers.

Like esters, polyglycols have an affinity to specific metals, such as brass or phosphate bronze. Because of their good load-carrying ability and film strength, they are frequently used in large worm and planetary gears.

Silicones and perfluoropolyethers (PFPEs) are compatible with nearly all gearing plastics. They are suitable for broad temperature

applications — from -90°C to over 250°C — and have exceptional, low-temperature torque characteristics. PFPEs are also resistant to chemically aggressive environments and will not dissolve in the presence of fuel or brake fluid. Nor will they form sludge. In addition, some PFPEs have very low vapor pressure, which is essential for vacuum and aerospace applications where outgassing can be problematic.

Polyphenylethers (PPEs) are not widely used in gear applications. However, these synthetic oils have high radiation resistance. In medical or dental applications, where radiation sterilization is mandatory, a PPE would be an ideal choice for gearing.

Hold The Ice A leading appliance control manufacturer uses Fluorocarbon Gel 807 to achieve 500,000 cycles for a linear-style damper, and 1.2 million cycles for a rotary damper.

Refrigerators use dampers to regulate the flow of cold air from the freezer to a fresh food compartment. Automatic dampers are actuated by timer motors or solenoids, which are controlled by temperature sensors. If the crisper gets too cold, the damper is closed; too warm, the damper is opened to increase air flow from the freezer.

Typically, dampers consist of two interfacing, slotted surfaces, one stationary and one sliding. They can be rotary or linear in design. In either case, ice crystals can build up on the interfacing surfaces, increasing strain on the drive components. However, if the damper surfaces are coated with a thin film of water-resistant grease, ice build-up is minimized and the surfaces slide easily — reducing strain on the drive and wear of the damper components.

Nye's Fluorocarbon Gel 807 is a good fit for this type of application. It is a blend of PTFE-thickened, super-refined, plastic-compatible synthetic hydrocarbon oils for lubricating and sealing applications. The gel is water-resistant and suitable for operating environments between -40°C and 100°C. All components of this grease are listed by the US Food and Drug Administration as suitable for incidental food contact.



12 Howland Road Fairhaven, Massachusetts 02719 USA
Phone 508-996-6721 Fax 508-997-5285 E-Mail techhelp@nyelubricants.com



FM 37483
QS 9000 / ISO 9001 Registered